

ISL78205EVAL2Z Evaluation Board Setup Procedure

The ISL78205EVAL2Z board is used to demonstrate the compact size and operations of synchronous/asynchronous buck using the ISL78205.

The ISL78205EVAL2Z board input voltage range is 3V to 40V.

The output voltage is set to 5V and can be changed by using the voltage feedback resistors. Note that to change to a higher output voltage, the output capacitors' voltage ratings have to be checked.

The board output current is 2A typical. The board is set at to a default overcurrent threshold of 3.6A. The OC threshold can be programmed by R15 at the ILIMIT pin.

The ISL78205EVAL2Z board has an optional diode D1 for asynchronous buck configuration.

The board is set to a default frequency of 500kHz. The frequency can be programmed by R8 at the FS pin.

The board can be synchronized to the external clock. Multiple ISL78205EVAL2Z boards can be synchronized simply by connecting their SYNC pins together.

Recommended Equipment

- 0V to 40V power supply with at least 3A source current capability
- Load capable of sinking current up to 3A
- Multimeters
- Oscilloscope

Quick Startup

1. Connect the power source to the input terminals P1(VIN+) and P2(GND). Connect the load terminals to the buck outputs P3(VOUT+) and P4(GND). Make sure the setup is correct prior to applying any power or load to the board.
2. Adjust the power source to 12V and turn it on.
3. Verify the output voltage is 5V and use the oscilloscope to monitor the phase node waveforms through JP2.

Asynchronous Buck Configuration

To configure the board to asynchronous buck, remove R19 and change R20 (on bottom of the board) to 0Ω to ensure that Q1 is securely off.



FIGURE 1A. TOP



FIGURE 1B. BOTTOM

FIGURE 1. ISL78205EVAL2Z BOARD IMAGES

Application Note 1773

TABLE 1. CONNECTORS/TEST POINTS DESCRIPTIONS

REF DES	NAME	DESCRIPTION
P1	VIN+	Positive terminal of buck inputs.
P2	GND	Ground terminal of buck inputs.
P3	VOUT+	Positive terminal of buck outputs.
P4	GND	Ground terminal of buck outputs.
TP1	VOUT+	Test point for VOUT+.
TP2	GND	Ground test point used for monitoring outputs.
TP3	PGOOD	Test point used to monitor PGOOD.
TP4	SYNC	Used for synchronization configuration. Option 1: to apply external clock for the IC to be synchronized with. Option 2: to synchronize multiple ISL78205, simply connect those SYNC pins together.
TP5	VCC	Test point used to monitor VCC.
TP10	VIN+	Test point for VIN+.
TP11	GND	Ground test point used for monitoring inputs.
JP1	EN	Use this connector to control IC ON/OFF.
JP2	PHASE	Test points used to monitor PHASE node waveforms. For monitoring purposes only. Do not short it with jumper.

ISL78205EVAL2Z Board Schematic

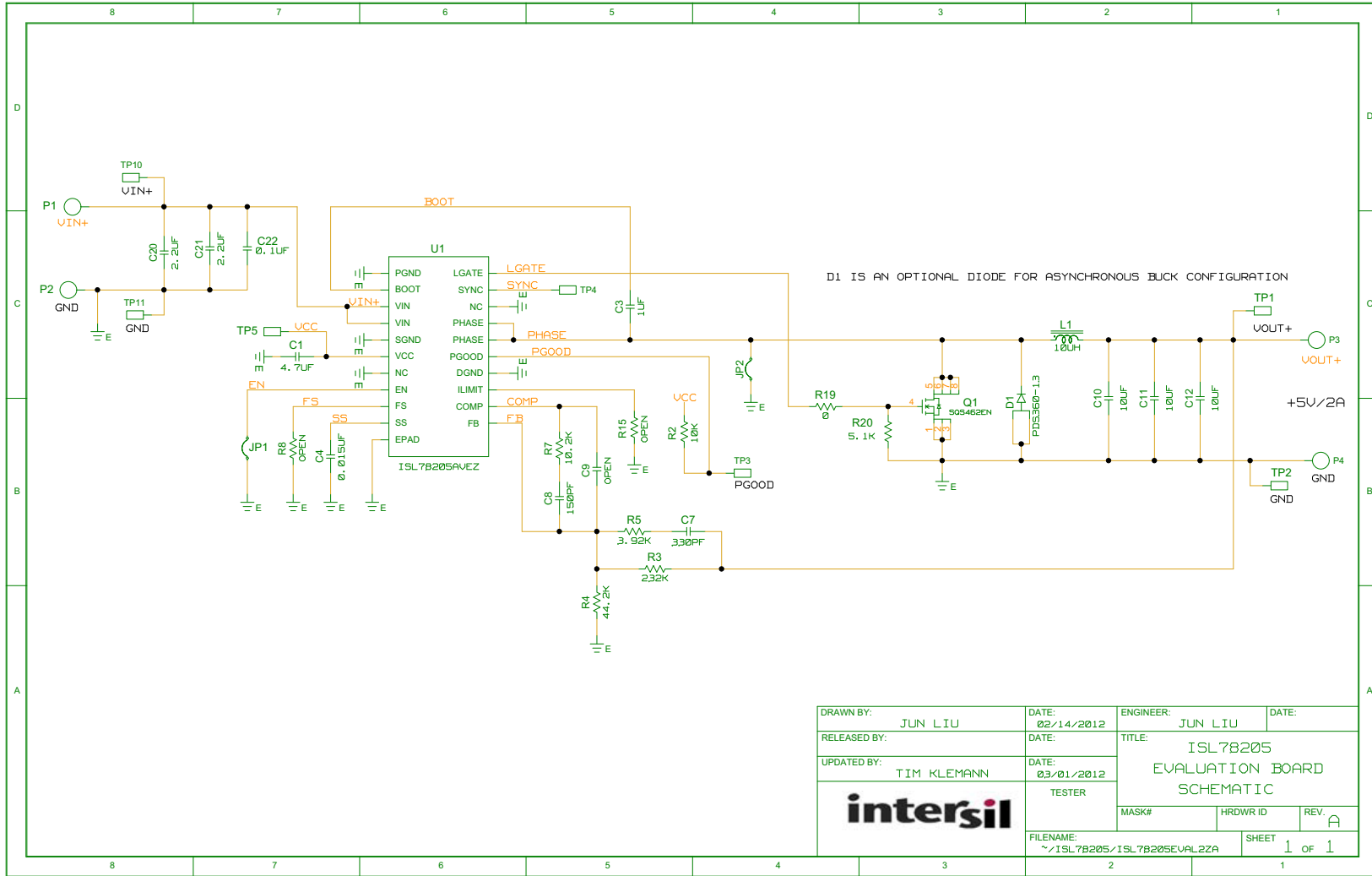

FIGURE 2. ISL78205EVAL2Z BOARD SCHEMATIC

Board Layouts

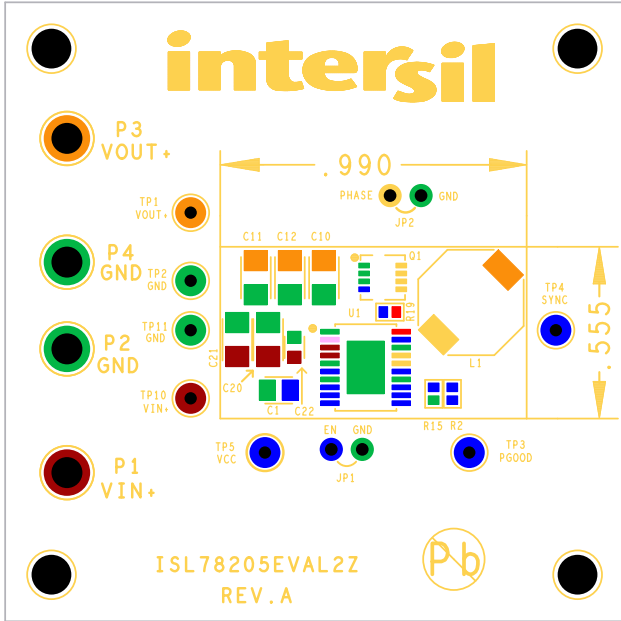

FIGURE 3. SILKSCREEN TOP COMPONENTS

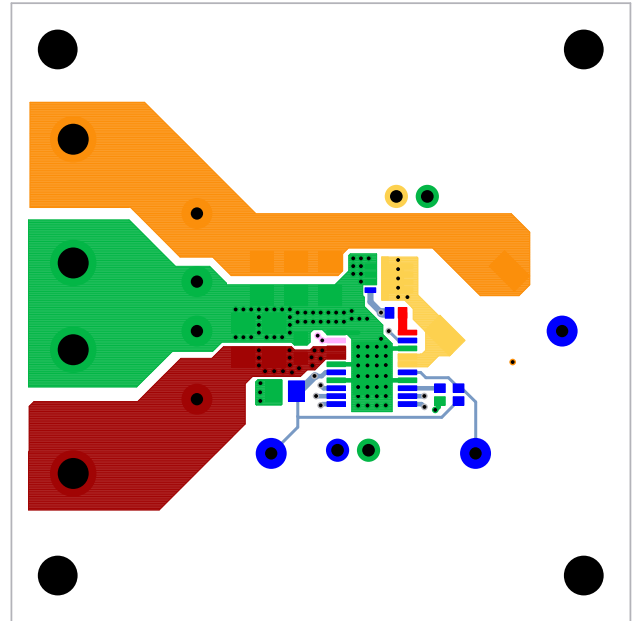

FIGURE 4. TOP LAYER

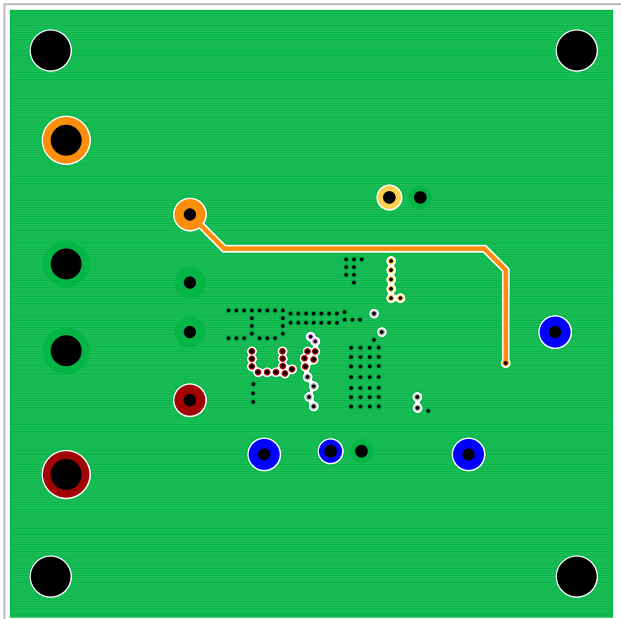

FIGURE 5. 2nd LAYER

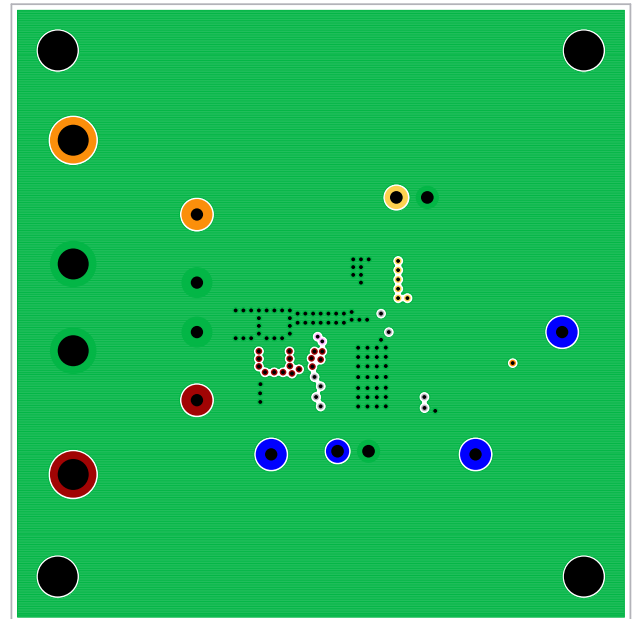

FIGURE 6. 3rd LAYER

Board Layouts (Continued)

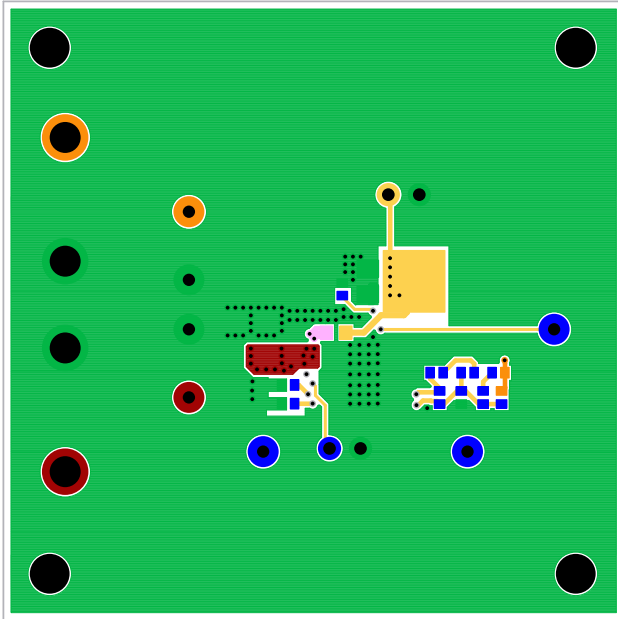

FIGURE 7. BOTTOM LAYER

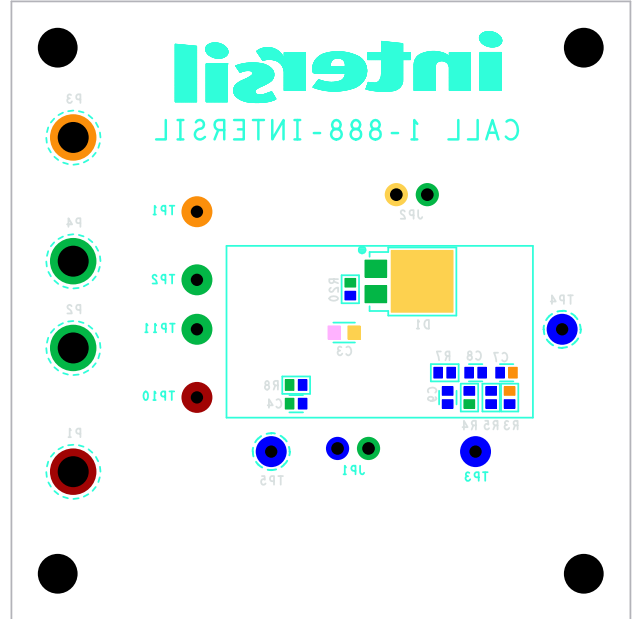

FIGURE 8. SILKSCREEN BOTTOM COMPONENTS

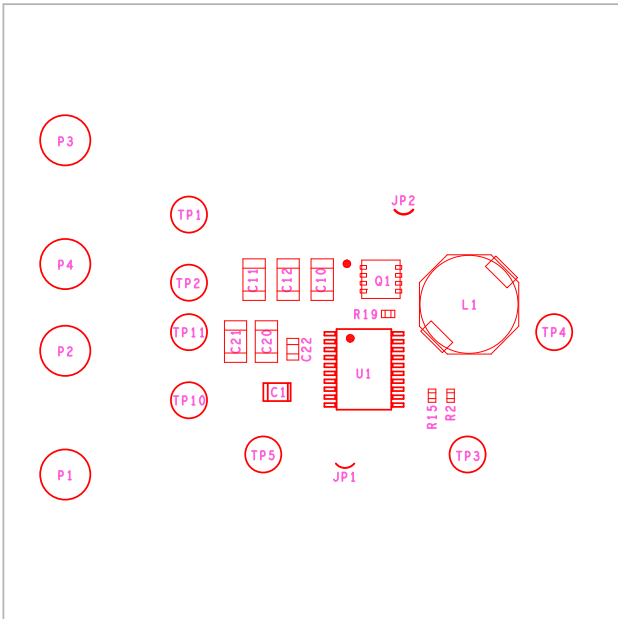

FIGURE 9. TOP COMPONENT ASSEMBLY

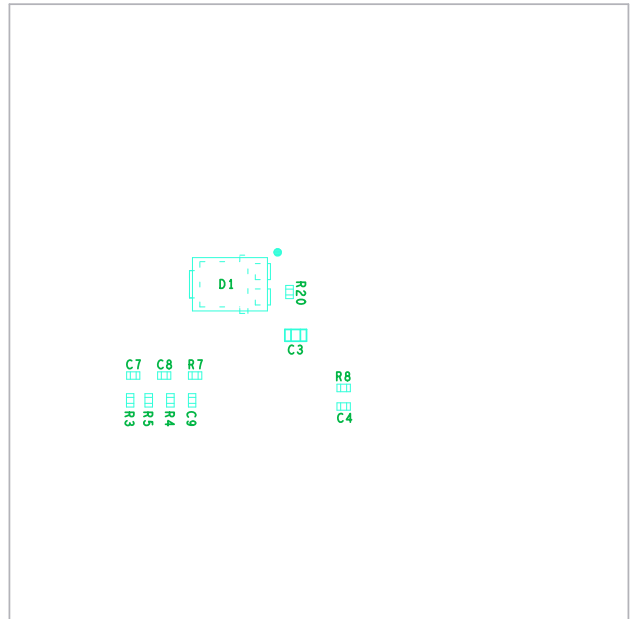

FIGURE 10. BOTTOM COMPONENT ASSEMBLY (MIRRORED)

Application Note 1773

TABLE 2. BILL OF MATERIALS

REF DES	PART NUMBER	QTY	DESCRIPTION	MANUFACTURER
C3	C1608X7R1C105K	1	CAP, SMD, 0603, 1.0μF, 16V, 10%, X7R, ROHS	TDK
C10, C11, C12	C3216X7R1C106K	3	CAP, SMD, 1206, 10μF, 16V, 10%, X7R, ROHS	TDK
C1	GRM21BR71A475KA73L	1	CAP, SMD, 0805, 4.7μF, 10V, 10%, X7R, ROHS	MURATA
C20, C21	GRM31CR71H225KA88L	2	CAP, SMD, 1206, 2.2μF, 50V, 10%, X7R, ROHS	MURATA
C8	ECU-E1H151KBQ	1	CAP, SMD, 0402, 150pF, 50V, 10%, NP0, ROHS	PANASONIC
C4	VARIOUS	1	CAP, SMD, 0402, 0.015μF, 16V, 10%, X7R, ROHS	VARIOUS
C7	VARIOUS	1	CAP, SMD, 0402, 330pF, 50V, 10%, X7R, ROHS	VARIOUS
C9	N/A	0	CAP, SMD, 0402, DNP-PLACE-HOLDER, ROHS	N/A
C22	VARIOUS	1	CAP, SMD, 0603, 0.1μF, 50V, 10%, X7R, ROHS	VARIOUS
L1	SD8350-100-R	1	COIL-PWR INDUCTOR, SMD, 9.5X8.3, 10μH, 20%, 4A, 31.4mΩ, ROHS	COILTRONICS
D1	PDS360-13	1	DIODE-SCHOTTKY, SMD, POWERDI5, 60V, 3A, ROHS	DIODES INC.
U1	ISL78205AVEZ	1	IC-2.5A BUCK CONTROLLER, 20P, HTSSOP, ROHS	INTERSIL
Q1	SQS462EN	1	TRANSISTOR-MOS, N-CHANNEL, 8P, PWRPAK, 60V, 8A, ROHS	VISHAY
R19	VARIOUS	1	RES, SMD, 0402, 0Ω, 1/16W, 5%, ROHS	VARIOUS
R2	VARIOUS	1	RES, SMD, 0402, 10k, 1/16W, 1%, ROHS	VARIOUS
R7	VARIOUS	1	RES, SMD, 0402, 10.2k, 1/16W, 1%, ROHS	VARIOUS
R3	VARIOUS	1	RES, SMD, 0402, 232k, 1/16W, 1%, ROHS	VARIOUS
R5	VARIOUS	1	RES, SMD, 0402, 3.92k, 1/16W, 1%, ROHS	VARIOUS
R4	VARIOUS	1	RES, SMD, 0402, 44.2k, 1/16W, 1%, ROHS	VARIOUS
R20	VARIOUS	1	RES, SMD, 0402, 5.1k, 1/16W, 1%, ROHS	VARIOUS
R8, R15	N/A	0	RES, SMD, 0402, DNP-PLACE-HOLDER, ROHS	N/A

Intersil Corporation reserves the right to make changes in circuit design, software and/or specifications at any time without notice. Accordingly, the reader is cautioned to verify that the Application Note or Technical Brief is current before proceeding.

For information regarding Intersil Corporation and its products, see www.intersil.com